

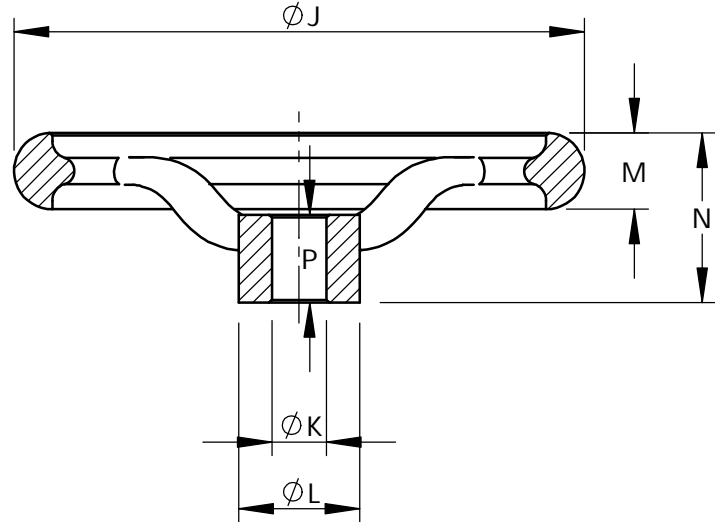

engineering cataloge 2008

HANDWHEELS

Material: Cast Iron.



Cat. No.	J	K	L	M	N	P	Handle
HWCI / 0080	80	10	27	14	35	24	N/A
HWCI / 0100	100	10	29	15	38	26	N/A
HWCI / 0125	125	10	33	16	41	28	M6
HWCI / 0150	150	15	35	17	44	30	M8
HWCI / 0200	200	15	43	22	58	38	M10
HWCI / 0250	250	20	50	26	63	42	M10
HWCI / 0300	300	20	55	26	66	45	M12
HWCI / 0350	350	25	65	30	76	50	M16
HWCI / 0400	400	25	75	34	83	50	M16
HWCI / 0500	500	25	83	34	88	60	M16

HANDLES

Material: Mild Steel – Chrome Plated.

Cat. No.	Q	R	S	T
GRIP / 0006	60	M6	10	16
GRIP / 0008	75	M8	12	20
GRIP / 0010	98	M10	18	25
GRIP / 0012	125	M12	25	32
GRIP / 0016	137	M16	25	36

