



engineering catalogue 2008

**STOCK MITRE GEARS
1.5MOD – 4.0MOD
32DP – 3 DP**

**STOCK BEVEL GEARS
1.5MOD – 4.0MOD
12DP – 6DP**

STOCK MITRE GEARS PITCH - 1.5 MOD TO 4 MOD

Material - S1045 Steel
 Tooth Pressure Angle - 20°

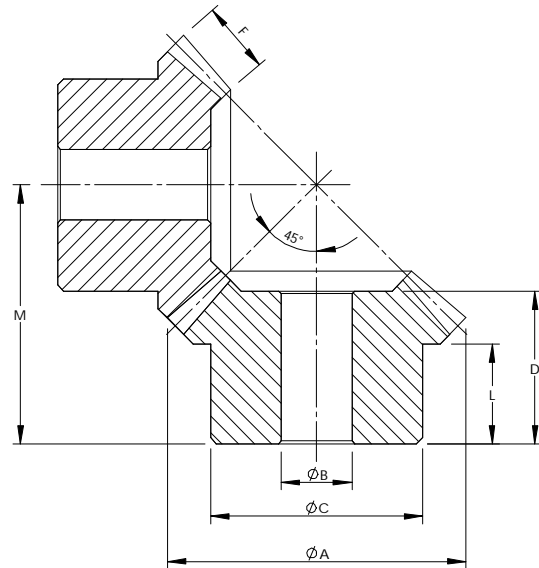

Catalogue No.	No. Teeth	Pitch MOD	Pitch Dia.	A	B	C	D	F	L	M
16M1.5M	16	1.5	24	26.1	8	20.3		6	12	26
20M1.5M	20	1.5	30	32.1	10	22	18	10	8.5	27.4
16M2.0M	16	2	32	34.8	10	25.3		8	14	33
20M2.0M	20	2	40	42.8	10	32	22	12	12	35.78
25M2.0M	25	2	50	52.8	12	40	25	14	12.3	42.28
20M2.5M	20	2.5	50	53.5	12	40	27	12	16	45.93
25M2.5M	25	2.5	62.5	66	15	50	30	15	16	52.98
20M3.0M	20	3	60	64.2	15	45	31	18	13.6	51
25M3.0M	25	3	75	79.2	15	55	34	20	16	60
30M3.0M	30	3	90	94.2	20	60	36	22	17	68
30M3.5M	30	3.5	105	109.9	20	70	43.5	30	19	78.02
25M4.0M	25	4	100	105.6	20	70	40	28	18	73.50
30M4.0M	30	4	120	125.6	25	80	43	32	16	83.67

Dimensions in MM

STOCK MITRE GEARS PITCH - 32DP TO 3DP

Material - S1045 Steel
Tooth Pressure Angle - 20°

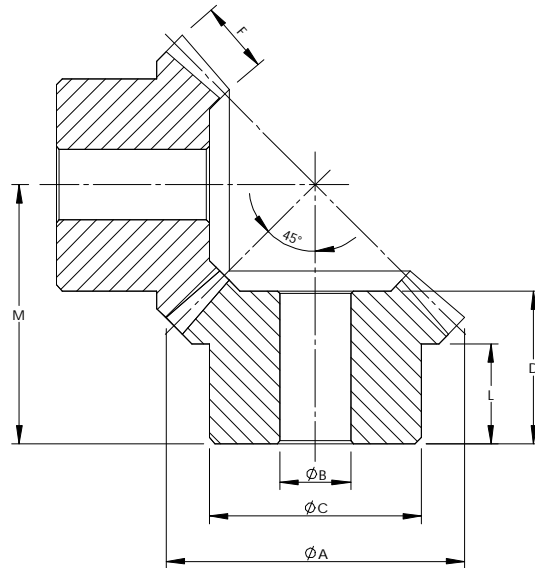

Catalogue No.	Product Code	No. Teeth	Pitch in DP	Pitch Dia.	A	B	C	D	F	L	M
24D32M	22S7001	24	32	0.750"	0.794"	0.250"	1/2"	0.35"	5/32"	0.20"	0.650"
24D24M		24	24	1.000"	1.059"	0.375"	3/4"	1/2"	1/4"	9/32"	0.875"
20D16M		20	16	1.250"	1.338"	0.438"	1"	3/4"	5/16"	1/2"	1.250"
15D12M		15	12	1.250"	1.368"	0.438"	1"	3/4"	5/16"	1/2"	1.250"
18D12M		18	12	1.500"	1.618"	0.500"	1.1/4"	1"	7/16"	5/8"	1.500"
21D12M		21	12	1.750"	1.867"	0.500"	1.3/8"	1.1/16"	7/16"	11/16"	1.750"
24D12M		24	12	2.000"	2.118"	0.625"	1.5/8"	1.1/4"	1/2"	13/16"	2.000"
20D10M		20	10	2.000"	2.141"	0.625"	1.5/8"	1.1/4"	1/2"	13/16"	2.000"
25D10M		25	10	2.500"	2.641"	0.750"	2"	1.1/2"	5/8"	15/16"	2.437"
24D8M		24	8	3.000"	3.176"	0.750"	2.1/4"	1.5/8"	3/4"	1.1/16"	2.750"
24D8MX		24	8	3.000"	3.176"	1.000"	2.1/4"	1.5/8"	3/4"	1.1/16"	2.750"
28D8M		28	8	3.500"	3.676"	1.000"	2.1/2"	2"	7/8"	1.1/8"	3.250"
32D8M		32	8	4.000"	4.176"	1.000"	3"	2.3/16"	1"	1.5/16"	3.625"
24D6M		24	6	4.000"	4.235"	1.000"	3"	2.3/16"	1"	1.5/16"	3.625"
25D5M		25	5	5.000"	5.283"	1.125"	3.3/4"	2.3/4"	1.1/4"	1.5/8"	4.500"
24D4M		24	4	6.000"	6.353"	1.250"	4.1/2"	3.1/8"	1.1/2"	1.3/4"	5.250"
21D3M		21	3	7.000"	7.471"	2.000"	5.1/2"	3.1/2"	1.3/4"	2"	6.000"

Dimensions in Inches.

STOCK BEVEL GEARS
RATIO 1:2
1.5 MOD TO 4.0 MOD

Material - S1045 Steel
Tooth Pressure Angle - 20°

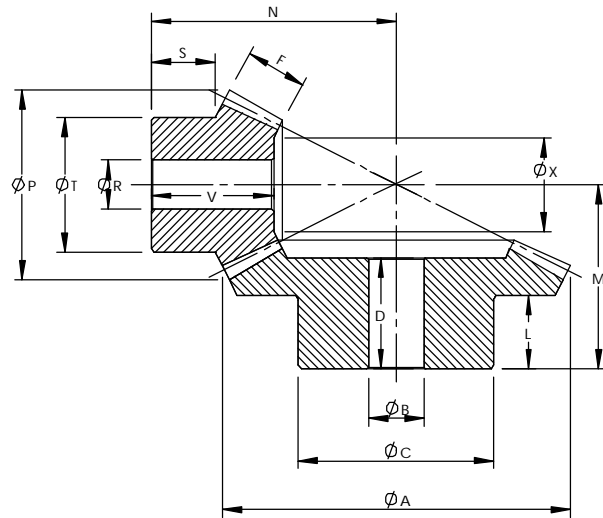

Ratio 1 : 2

Cat No.	No. Teeth	Pitch MOD	Pitch Dia.	A	B	C	D	F	L	M	N	P	R	S	T	V	X
32M1.5P16	16 32	1.5	24 48	49.3	12	32	17	8 8	10	27.45	35.83	26.7	10	11.3	21	18	
32M2.0P16	16 32	2.0	32 64	65.8	12	40	21	10 10	10	35.21	45.41	35.6	10	12.2	26	21	
32M2.5P16	16 32	2.5	40 80	82.2	15	50	20	12 12	10	39.10	55.88	44.4	12	14.4	34	25	
32M3.0P16	16 32	3.0	48 96	98.7	15	60	24	15 15	10	45.31	61.64	53.4	15	11.6	40	25	
32M3.5P16	16 32	3.5	56 112	115.1	20	70	24	18 18	10	38.77	72.33	62.3	15	14.4	48	30	
32M4.0P16	16 32	4.0	64 128	131.6	20	80	24	20 20	10	52.42	80.81	71.1	20	13.4	50	32	

Dimensions in MM.

STOCK BEVEL GEARS
RATIO 1:3 - 1:4
1.5 MOD TO 4.0 MOD

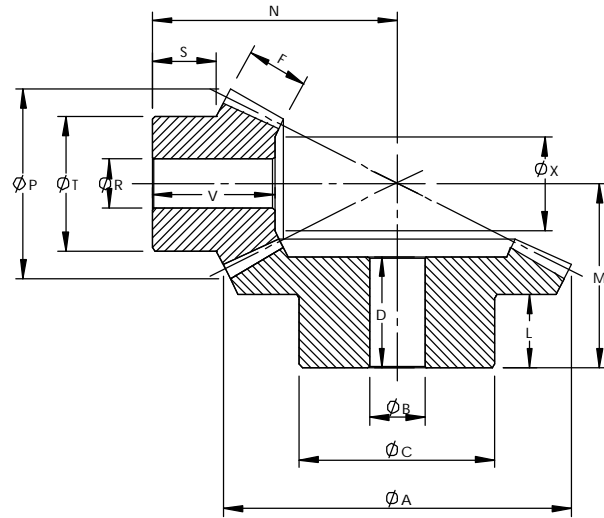

Material - S1045 Steel
Tooth Pressure Angle - 20°

Ratio 1 : 3

Cat No.	No. Teeth	Pitch in DP	Pitch Dia.	A	B	C	D	F	L	M	N	P	R	S	T	V	X
48M1.5P16	16 48	1.5	24 72	72.9	15	50	17	12 12	10	27.27	46.44	26.9	10	11.7	20	23	
48M2.0P16	16 48	2.0	32 96	97.3	15	60	19	15 15	10	32.9	61.76	35.8	12	12.4	26	27	
48M2.5P16	16 48	2.5	40 120	121.6	20	70	21	18 18	10	39.23	74.41	44.7	12	13	32	30	
48M3.0P16	16 48	3.0	48 144	145.9	20	80	23	18 18	10	45.2	86.25	53.7	15	12.1	40	30	
48M3.5P16	16 48	3.5	56 168	170.2	20	90	24	22 22	10	49.48	100.29	62.6	15	15	48	35.5	
48M4.0P16	16 48	4.0	64 192	194.5	22	100	25	25 25	10	54.2	112.73	71.6	20	15.2	55	38.5	

Dimensions in MM.

Ratio 1 : 4

Cat No.	No. Teeth	Pitch in DP	Pitch Dia.	A	B	C	D	F	L	M	N	P	R	S	T	V	X
64M1.5P16	16 64	1.5	24 96	96.7	15	70	19	12 12	10	30.53	61.02	26.9	10	12.2	18	24	
64M2.0P16	16 64	2.0	32 128	129	20	80	20	15 15	10	35.79	73.07	35.9	12	8.2	25	23	
64M2.5P16	16 64	2.5	40 160	161.2	20	90	24	18 18	10	42.77	92.49	44.9	15	8.2	30	26	
64M3.0P16	16 64	3.0	48 192	193.5	20	100	24	22 22	10	46.41	108.05	53.8	15	11	40	32	
64M3.5P16	16 64	3.5	56 224	225.7	25	100	43	25 25	22	69.32	132.13	62.8	15	19.1	48	43	
64M4.0P16	16 64	4.0	64 256	257.9	28	120	42	30 30	20	71.72	148.21	71.7	20	18.5	50	48	

Dimensions in MM.

STOCK BEVEL GEARS
RATIOS 2:3 - 1:2
6DP TO 12DP

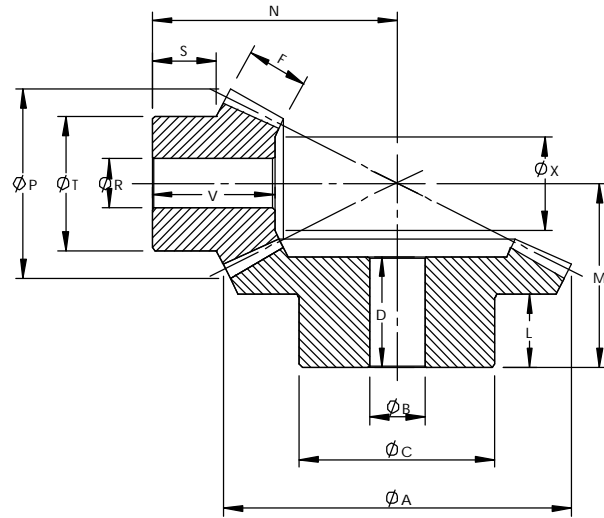

Material - S1045 Steel
Tooth Pressure Angle - 20°

Ratio 2 : 3

Cat No.	No. Teeth	Pitch in DP	Pitch Dia.	A	B	C	D	F	L	M	N	P	R	S	T	V	X
18D12P27	18	12	1.500"					1/2"			1.875"	1.669"	0.500"	5/8"	1.1/4"	1.1/8"	13/16"
27D12P18	27	12	2.250"	2.322"	0.625"	1.5/8"	1.3/16"	1/2"	3/4"	1.750"							
20D10P30	20	10	2.000"					5/8"			2.500"	2.203"	0.625"	7/8"	1.3/4"	1.7/16"	1.3/16"
30D10P20	30	10	3.000"	3.086"	0.625"	2.1/4"	1.1/2"	5/8"	1"	2.250"							
20D8P30	20	8	2.500"					3/4"			3.000"	2.754"	0.750"	15/16"	2"	1.5/8"	1.1/2"
30D8P20	30	8	3.750"	3.858"	0.875"	2.3/4"	1.5/8"	3/4"	1"	2.625"							

Dimensions in Inches.

Ratio 1 : 2

Cat No.	No. Teeth	Pitch in DP	Pitch Dia.	A	B	C	D	F	L	M	N	P	R	S	T	V	X
18D12P36	18	12	1.500"					9/16"			2.125"	1.694"	0.500"	9/16"	1.1/4"	1.1/16"	7/8"
36D12P18	36	12	3.000"	3.052"	0.625"	2.1/4"	1"	9/16"	1/2"	1.625"							
24D12P48	24	12	2.000"					3/4"			2.875"	2.193"	0.500"	11/16"	1.1/2"	1.7/16"	1.3/16"
48D12P24	48	12	4.000"	4.052"	0.625"	2.3/4"	1.3/16"	3/4"	5/8"	2.000"							
20D10P40	20	10	2.000"					3/4"			3.000"	2.233"	0.625"	15/16"	1.3/4"	1.5/8"	1.3/16"
40D10P20	40	10	4.000"	4.062"	0.750"	2.1/2"	1.1/2"	3/4"	3/4"	2.250"							
25D10P50	25	10	2.500"					1"			3.500"	2.733"	0.750"	7/8"	2"	1.13/16"	1.7/16"
50D10P25	50	10	5.000"	5.062"	0.875"	3.1/4"	1.11/16"	1"	1"	2.625"							
16D8P32	16	8	2.000"					3/4"			3.000"	2.291"	0.750"	7/8"	1.3/4"	1.5/8"	1.3/16"
32D8P16	32	8	4.000"	4.078"	0.875"	2.3/4"	1.5/8"	3/4"	1"	2.500"							
20D8P40	20	8	2.500"					1"			3.750"	2.791"	0.750"	1.1/8"	2.1/8"	2.1/16"	1.7/16"
40D8P20	40	8	5.000"	5.078"	1.000"	3.1/2"	1.15/16"	1"	1.1/4"	2.875"							
18D6P36	18	6	3.000"					1.1/8"			4.375"	3.387"	1.000"	1.1/4"	2.1/2"	2.1/4"	1.13/16"
36D6P18	36	6	6.000"	6.104"	1.125"	4"	2.1/4"	1.1/8"	1.1/2"	3.500"							
21D6P42	21	6	3.500"					1.1/4"			5.000"	3.887"	1.000"	1.5/16"	2.3/4"	2.1/2"	2.1/8"
42D6P21	42	6	7.000"	7.104"	1.125"	4"	2.1/4"	1.1/4"	1.1/2"	3.750"							

Dimensions in Inches.

STOCK BEVEL GEARS
RATIOS 1:3 - 1:4 - 1:6
6DP TO 12DP

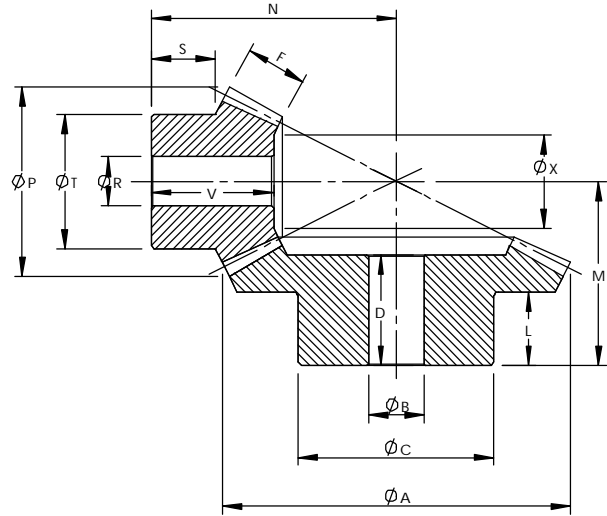

Material - S1045 Steel
Tooth Pressure Angle - 20°

Ratio 1 : 3

Cat No.	No. Teeth	Pitch in DP	Pitch Dia.	A	B	C	D	F	L	M	N	P	R	S	T	V	X
15D12P45	15	12	1.250"					5/8"			2.500"	1.464"	0.375"	9/16"	1"	1.3/16"	3/4"
45D12P15	45	12	3.750"	3.784"	0.625"	2.1/4"	1.1/16"	5/8"	5/8"	1.625"							
15D10P45	15	10	1.500"					3/4"			3.000"	1.756"	0.500"	5/8"	1.1/4"	1.3/8"	7/8"
45D10P15	45	10	4.500"	4.540"	0.750"	2.3/4"	1.5/16"	3/4"	3/4"	2.000"							
16D8P48	16	8	2.000"					1"			4.000"	2.322"	0.625"	15/16"	1.5/8"	1.7/8"	1.3/16"
48D8P16	48	8	6.000"	6.051"	0.750"	3.3/4"	1.5/8"	1"	1"	2.500"							
15D6P45	15	6	2.500"					1.1/4"			5.250"	2.930"	0.875"	1.3/8"	2.1/8"	2.5/8"	1.7/16"
45D6P15	45	6	7.500"	7.568"	1.125"	4.1/2"	2"	1.1/4"	1.1/4"	3.125"							

Dimensions in Inches.

Ratio 1 : 4

Cat No.	No. Teeth	Pitch in DP	Pitch Dia.	A	B	C	D	F	L	M	N	P	R	S	T	V	X
15D12P60	15	12	1.250"					3/4"			3.125"	1.472"	0.375"	9/16"	1"	1.3/8"	3/4"
60D12P15	60	12	5.000"	5.025"	0.625"	3"	1.1/8"	3/4"	3/4"	1.750"							
15D10P60	15	10	1.500"					3/4"			3.875"	1.767"	0.500"	13/16"	1.1/4"	1.5/8"	15/16"
60D10P15	60	10	6.000"	6.030"	0.750"	3.1/2"	1.1/2"	3/4"	7/8"	2.250"							
16D8P64	16	8	2.000"					1"			5.250"	2.333"	0.625"	1.3/16"	1.5/8"	2.1/4"	1.5/16"
64D8P16	64	8	8.000"	8.038"	0.875"	4.1/2"	1.3/4"	1"	15/16"	2.750"							
15D6P60	15	6	2.500"					1.3/8"			6.750"	2.945"	0.750"	1.5/8"	2"	3.1/16"	1.9/16"
60D6P15	60	6	10.000"	10.051"	1.000"	4.1/2"	2.1/16"	1.3/8"	1.3/16"	3.250"							

Dimensions in Inches.

Ratio 1 : 6

Cat No.	No. Teeth	Pitch in DP	Pitch Dia.	A	B	C	D	F	L	M	N	P	R	S	T	V	X
15D12P90	15	12	1.250"					7/8"			4.375"	1.478"	0.375"	9/16"	1.1/8"	1.1/2"	7/8"
90D12P15	90	12	7.500"	7.517"	0.750"	4.1/2"	1.1/4"	7/8"	5/8"	1.875"							
15D10P90	15	10	1.500"					1"			5.250"	1.774"	0.500"	11/16"	1.1/4"	1.3/4"	1"
90D10P15	90	10	9.000"	9.020"	0.875"	5"	1.1/2"	1"	3/4"	2.250"							

Dimensions in Inches.

Full Size Teeth of 20° Pressure Angle in Inch and Metric Sizes

